

**ADAPTER PRODUCT GUIDE**



*RH-SPADE  
W/O ADAPTER*



*LH-SPADE  
W/O ADAPTER*



*CENTER-SPADE  
W/O ADAPTER*



*BOLT-ON ADAPTER*

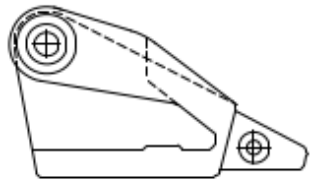
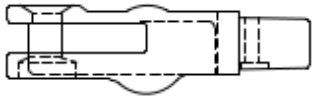

*BOLT ON CORNER ADAPTER  
(1 Bolt)*

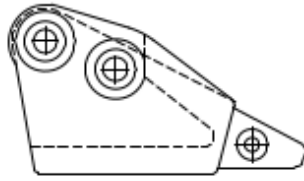

*BOLT ON CORNER ADAPTER  
(2 Bolts)*



*EXCAVATOR ADAPTER  
(CENTER)*

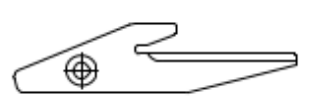

*BACK HOE ADAPTER  
(CENTER)*

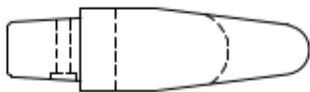

*CENTER W/O  
LOADER ADAPTER*



*RH W/O  
LOADER ADAPTER*

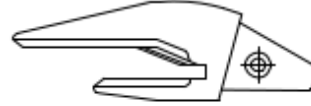

*LH W/O  
LOADER ADAPTER*

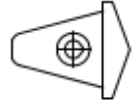
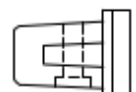

*WELD-ON  
NOSE*

## CAT TOOTH PROFILE GUIDE

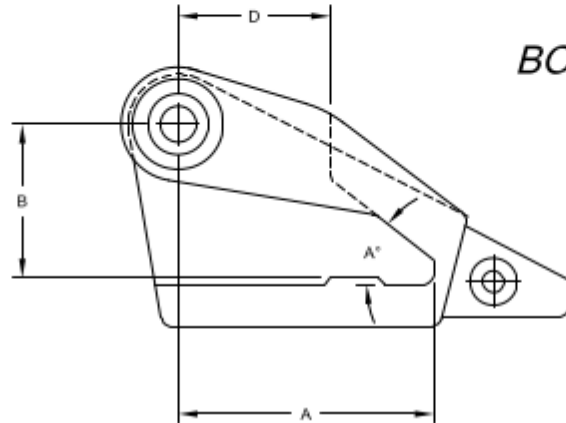

*BOLT ON CORNER ADAPTER  
(1 Bolt)*

ItemNumber	Category	ItemDescription	Weight	A	B	C	D	A*	B*	Bolt	NutBoltQtyReqd-Each
1U2208	J200	ADAPTER CORNER 910, 930	8.8								
1U2209	J200	ADAPTER CORNER 910, 930	8.8								
3G4258	J250	ADAPTER B/O 943,953	21.2	5 3/4	4 3/16	1 1/16	3	43		1 X 3 1/4	1
3G4259	J250	ADAPTER, B/O 943,953	21.2	5 3/4	4 3/16	1 1/16	3	43		1 X 3 1/4	1
3G4308	J300	ADAPTER B/O 950,953	32.9	7	4 3/4	1 1/16	4 1/16	39		1 1/4 x 4	1
3G4309	J300	ADAPTER B/O 950,953	32.9	7	4 3/4	1 1/16	4 1/16	39		1 1/4 x 4	1
3G8308	J300	ADAPTER B/O 966	35.9	8	5 1/2	1 9/16	5 1/8	47		1 1/4 x 4	1
3G8309	J300	ADAPTER B/O 966	35.9	8	5 1/2	1 9/16	5 1/8	47		1 1/4 x 4	1
3G5358	J350	ADAPTER B/O 966,973	43.1	9 17/32	5 5/8	1 9/16	5 3/32	38		1 1/4 x 4	1
3G5359	J350	ADAPTER B/O 966,973	43.1	9 17/32	5 5/8	1 9/16	5 3/32	38		1 1/4 x 4	1
1U1358	J350	ADAPTER B/O LH	52.8	9 1/8	5 3/4	1 5/8	5 7/8	45		1 1/4 x 4	1
1U1359	J350	ADAPTER B/O RH	52.8	9 1/8	5 3/4	1 5/8	5 7/8	45		1 1/4 x 4	1

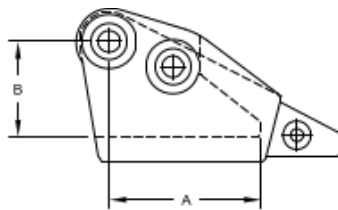

*BOLT ON CORNER ADAPTER  
(2 Bolts)*

ItemNumber	Category	ItemDescription	Weight	A	B
6I9251	J250	ADAPTER, 2 BOLT LH	29.5	7.48	6.61
6I9250	J250	ADAPTER, 2 BOLT RH	29.5	7.48	6.61
8E5308	J300	ADAPTER, 2 BOLT CORNER	39.6	7.87	6.42
8E5309	J300	ADAPTER, 2 BOLT CORNER	39.6	7.87	6.42
8E5358	J350	ADAPTER, 2 BOLT CORNER	56.5	9.6	7.09
8E5359	J350	ADAPTER, 2 BOLT CORNER	56.5	9.6	7.09

## CAT TOOTH PROFILE GUIDE

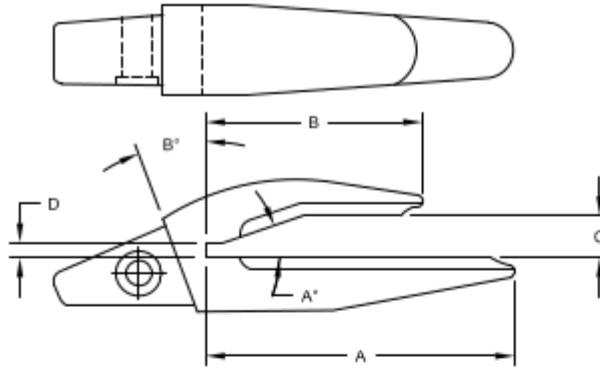

*EXCAVATOR ADAPTER  
CENTER*

Item Number	Category	Item Description	Weight	A	B	C	D	A'	B'	Bolt	Nut Bolt Qty Req'd-Each
6Y3224	J225	ADAPTER, W/O 446, E70	5.5	5 9/16	3 11/16	1 1/16	7/16	22	8		
8J7525	J250	ADAPTER, W/O 416, 426	3.09	3 15/16	1	1	1/4	23	14		
6Y3254	J250	ADAPTER, W/O E200	8.4	6 1/8	5	1 5/16	3/8	22	9		
3G6304	J300	ADAPTER W/O 215	17.3	8	4 9/16	1 5/16	9/16	22	8		
8E9490	J300	ADAPTER, W/O	16.2	8 1/4	5 7/8	1 9/16	1/2	23	12		
3G8354	J350	ADAPTER W/O 225	17.6	8 1/4	4 3/4	1 11/16	5/8	35	8		
6I6354	J350	ADAPTER, W/O	23	9	7 1/4	1 5/8	9/16	22	12		
6I6404	J400	ADAPTER, W/O 231, 326	27.9	9 1/2	6 3/4	1 7/8	3/4	22	9		
8E6464	J460	ADAPTER, W/O 235, E3000	43.9	11 1/8	7 3/8	2	7/16	24	9		
6I6464	J460	ADAPTER, W/O 235, E3001	41.8								
1U1553	J550	ADAPTER W/O	62.7								
3G9494	J550	ADAPTER W/O, 245, 992	71.5	14 1/4	12 5/8	2 5/8	1 1/16	22	15		
6I6604	J600	ADAPTER, W/O 375	116.6	14 1/2	12	3 1/8	1 3/8	22	9		
4T4704	J700	ADAPTER, W/O 994	146	18 1/8	13 1/8	3 1/16	1	22	15		

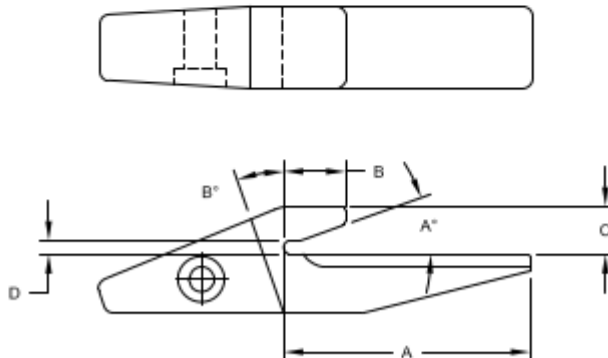

*BACK HOE ADAPTER  
CENTER*

Item Number	Category	Item Description	Weight	A	B	C	D	A'	B'	Bolt	Nut Bolt Qty Req'd-Each
3G0169	J250	ADAPTER W/O 926, 936	11.7	7 1/2	2 5/16	2	5/16	22	15		
1U1350	J350	ADAPTER W/O BTM. STRAP	21.1	10	7	1 13/16	11/16	22	14		

ALL MANUFACTURERS NAMES, NUMBER, SYMBOLS & DISCRPTIONS ARE USED FOR REFERENCE PURPOSES ONLY.  
IT IS NOT IMPLIED THAT ANY PART LISTED IS A PRODUCT OF THESE MANUFACTURERS.

## CAT TOOTH PROFILE GUIDE

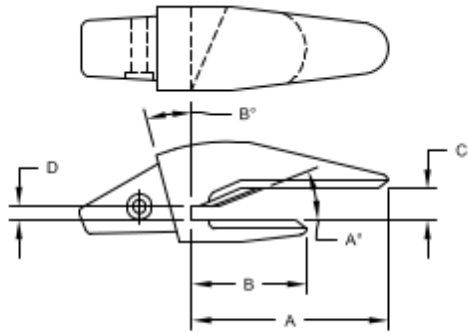

*RH W/O LOADER  
ADAPTER*

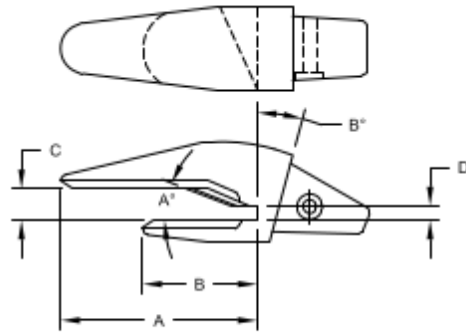

*LH W/O LOADER  
ADAPTER*

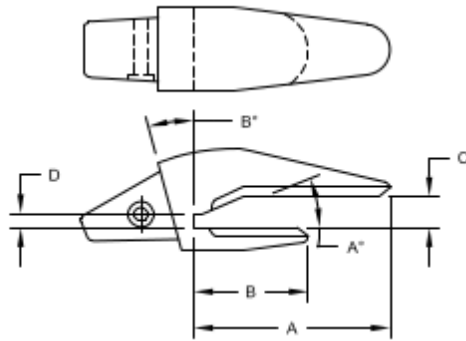

*CENTER W/O LOADER  
ADAPTER*

ItemNumber	Category	ItemDescription	Weight	A	B	C	D	A'	B'	Bolt	NutBoltQtyReqd-Each
8E0466	J460	ADAPTER, W/O LH FLUSH 988	52.8	13 3/4	4 1/8	2 3/16		23	13		
8E3465	J460	ADAPTER, W/O R/H 988	50.7	12 1/2	9	2 1/8	3/4	22	12		
8E0465	J460	ADAPTER, W/O RH FLUSH 988	52.8	13 3/4	4 1/8	2 3/16		23	13		
8E3464	J460	ADAPTER, W/O CTR 983,988	47.4	10 3/8	6 7/8	2 1/8	3/4	22	12		
8E3466	J460	ADAPTER, W/O LH 988	50.7	12 1/2	9	2 1/8	3/4	22	12		
3G9496	J550	ADAPTER W/O, 245,992	71	15	13 3/8	2 5/8	1 1/16	22	15		
3G9495	J550	ADAPTER W/O, 245,992	71	15	13 3/8	2 5/8	1 1/16	22	15		

## CAT TOOTH PROFILE GUIDE

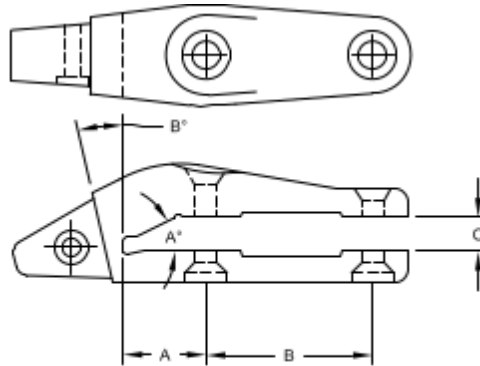

*BOLT-ON ADAPTER*

ItemNumber	Category	ItemDescription	Weight	A	B	C	D	A'	B'	Bolt	NutBoltQtyReqd-Each
9W6207	J200	ADAPTER B/O 416,426	4.8	1 31/32	2 15/16	7/8		23	14	5/8 X 2 1/2	2
9J4207	J200	ADAPTER, B/O	5.1	2 5/8	3 1/2	13/16		30	14		
1U0257	J250	ADAPTER B/O 943,953	18.9	2 3/4	4 7/8	1 1/16		23	14		
1U0307	J300	ADAPTER B/O 950,953	22.7	2 3/4	4 7/8	1 1/16		23	14		
4T4307	J300	ADAPTER B/O 950,963	30.4	3 3/16	6 1/2	1 5/16		23	14	1 X 4 1/4	2
3G9307	J300	ADAPTER B/O 966	29	3 3/8	6 5/16	1 5/16		23	14	1 1/4 X 4 1/2	2
3G7357	J300	ADAPTER B/O 966,977	40.5	3 3/8	6 9/32	1 5/16		22/30'	15	1 1/4 X 4 1/4	2
9W1304	J300	ADAPTER W/O	13.4	7 1/2	5 1/4	1 5/16	7/16	22	9		
3G3357	J350	ADAPTER B/O 966,977	40.5	3 7/8	5 7/8	1 11/16		24	14	1 1/4 X 5	2
1U1357	J350	ADAPTER B/O 980	39.6	4 1/32	6 1/8	1 13/16		20	14	1 1/4 x 5	2

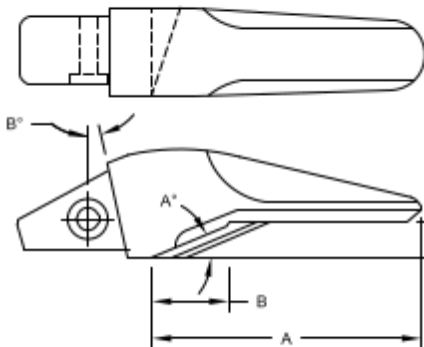

*RH-SPADE W/O  
ADAPTER*

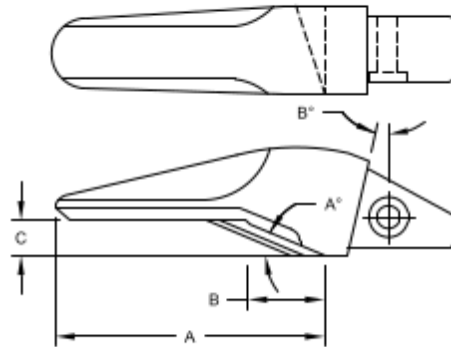

*LH-SPADE W/O  
ADAPTER*

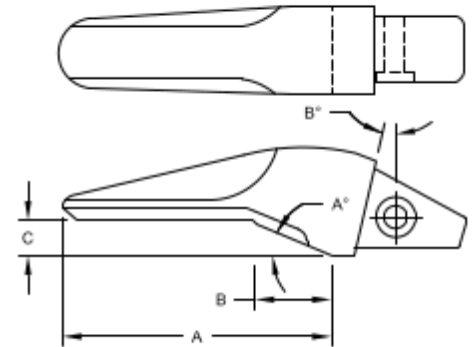

*CENTER-SPADE W/O  
ADAPTER*

ItemNumber	Category	ItemDescription	Weight	A	B	C	D	A'	B'	Bolt	NutBoltQtyReqd-Each
4T1204	J200	ADAPTER W/O FLUSH,931	4.6								
1U1254	J250	ADAPTER W/O FLUSH 936	12.5	9 1/4	2	1		22	13		
1U1304	J300	ADAPTER W/O FLUSH 966	17.4	9 3/8	2 5/16	1 1/16		22	14		
1U1354	J350	ADAPTER W/O FLSH 966	32.8	11 1/4	3 3/16	1 1/2		22	14		
8E0464	J460	ADAPTER, W/O CTR FLUSH 988	52.8	12 1/2	4 1/2	2 3/16		23	13		

ALL MANUFACTURERS NAMES, NUMBER, SYMBOLS & DISCRPTIONS ARE USED FOR REFERENCE PURPOSES ONLY.  
IT IS NOT IMPLIED THAT ANY PART LISTED IS A PRODUCT OF THESE MANUFACTURERS.